

**American Changer Corp.**  
**1400 NW 65<sup>th</sup> Place**  
**Ft. Lauderdale, FL 33309**

*Internet Address: [www.americanchanger.com](http://www.americanchanger.com)*

**Service Questions? e-mail: [service@americanchanger.com](mailto:service@americanchanger.com)**

# BILL DISPENSER

## OPERATIONS MANUAL

### SERIES AC7000/7005

**TOLL FREE**

**Parts & Service:(888)741-9840**

**Sales:(800)741-9840**

**Fax:(954)917-5204**

#### SECTION A: SET-UP & INSTALLATION

Uncrating & Setup.....	3
<b>Mounting instructions</b> .....	3-4
Filling the Hopper.....	4
Using the Dump Mode.....	4
DIP Switches.....	4-5
Fuses.....	5
Functional Descriptions.....	5-6
Indicator Lights.....	6
Coin Control Hopper (Filling).....	6
Wiring definitions.....	6

#### SECTION B: VALIDATOR

<b>INFORMATION</b> .....	7-13
CashCode Validator Information.....	7
CoinCo Validator information.....	9
SETTING UP THE COINCO.....	10
CLEARING A BILL JAM.....	11
CLEANING THE COINCO.....	12
Changing the belts.....	13

#### SECTION C: JCM HBP-10 HOPPER

<b>INFORMATION</b> .....	14-26
--------------------------	-------

#### SECTION D: TROUBLESHOOTING

<b>INFORMATION</b> .....	27
--------------------------	----

#### SECTION E: PARTS LISTS

Parts CoinCo Bill Validator.....	28-31
----------------------------------	-------

*CoinCo branches and Service centers are on the back cover of this manual.*

Rev. Bill B-06 Sept'02

#### Specifications

Operating voltage	120 VAC +10/-15 %
Power consumpt.(controller only, add dispenser and validator)	10w
Operating temperature	32 - 130 degrees Fahrenheit
Interface to HP-10 dispensers	24vdc & 12vdc 5 amps max.
Interface to Validators	120vac .5 amps max.

#### Warranty

CoinCo BA30B - BA30BB Validator

The CoinCo BA30B BA30BB Dollar Bill Validator is warranted for two years from date of purchase.

Cash Code Validator is warranted one year from time of purchase.

#### COVERED

¥ Defect in workmanship or material.

#### NOT COVERED

¥ Damage caused by physical abuse.

¥ Misapplication.

¥ Vandalism.

¥ End users attempt, on his own to repair item.

¥ cleaning maintenance.

It is the End User's responsibility to follow cleaning maintenance procedure outline on page B-2. Any unit coming in for repair requiring only a cleaning will be charged a flat rate of \$35.00 plus shipping and handling.

#### Dispensing System and Logic Board

The dispenser and logic board is warranted for one year from date of purchase.

#### COVERED

¥ Defects caused by material or workmanship.

#### NOT COVERED

¥ Damage caused by physical abuse.

¥ Misapplication.

¥ Vandalism.

¥ End Users attempt, on his own to repair.

**A Return material authorization number (RMA#) must be obtained before returning a unit for repair . A copy of invoices**

**must accompany any and all warrantee work.**

**Attention Please:**

THIS MACHINE IS DIFFERENT THAN OTHERS WE HAVE MADE IN THE PAST. IT HAS A BUILT-IN SURGE SUPPRESSOR, WHICH SUPPLIES VOLTAGE TO THE MACHINE FOR 1/2 MINUTE AFTER POWER IS REMOVED. PLEASE LET THE MACHINE SIT FOR 1/2 MINUTE WHEN ATTEMPTING TO RESET IT. (Look for the front display to extinguish.)

AC \_\_\_\_\_ S/N# \_\_\_\_\_

Tested By \_\_\_\_\_

Date \_\_\_\_\_

**Thank You,  
American Changer Corp.  
(888) 741-9840**

## UNCRATING AND SET-UP

Remove your Series AC7000/7005 dispenser from the shipping box. Open the door. (*The T-handle is a screw-in type and therefor, must be turned at least 10 times counter-clockwise until it opens.*) Inspect for any connectors or components that may have been dislodged during shipping. The lock and keys for your dispenser will be inside the manila envelope along with this manual. To install the lock, insert the cylinder into the round hole in the middle of the T-handle and push until it stops. Now turn the key and lock until you hear it "snap." Turn the key counter-clockwise ¼ turn and remove the keys.

**NOTE: The only way to get a duplicate set of keys made is to save the red tag that comes between the keys. This ID # starts with ACC #####.**

### TEST:

Before permanently installing the AC7000/7005, do a functional test to verify that there is no shipping damage to your new dispenser(s).

Extend the power cord through the hole in the back of the dispenser or the bottom and plug it into a **grounded 120vac outlet**. The dip switches are already set for a \$1 bill pay-out of the HP-10 dispenser, and the Bill validator is ready to accept \$5-\$10-\$20 dollar bills.

1. It will be necessary to remove the HP-10 bill dispenser from the shipping box at this time.
2. Taped to the top of the HP-10 is a set of keys. Open the bottom drawer of the HP-10 and remove the Bill Weight and the Dispenser Bill Support.  
**(In any miscounting errors, the miscounted bills will be placed in this drawer.)**

*The bracket that supports the HP-10 is on the right side of the cabinet. In front of the bracket is 7/16ths nut and locking bracket.*

3. Remove the nut and locking bracket.
4. Partial slide the HP-10 into the support bracket.
5. Plug the two wire harness connectors coming of the left side of the Main Logic Board into the back of the HP-10.
6. Slide the HP-10 the rest of the way into the support bracket and tighten down the locking bracket and 7/16-ths nut.
7. The front of the bill dispenser has a chrome bracket which helps the bills reach the slot in the bill opening. Attach this bracket with the two Phillips screws taped onto the unit.

To begin using the bill dispenser: plug the unit into a 120vac 3-prong outlet, fill the HP-10 Bill Dispenser with bills, and turn the on/off switch "ON".

Fill the HP-10 dispenser with at least 100 bills. On the main logic board turn the switch on the bottom right corner "ON". **(SEE FIG. 1 ON PG.3)** *The rocker switch has a "1" and "0" printed on it. When the "1" is pressed down the dispenser is "ON".*

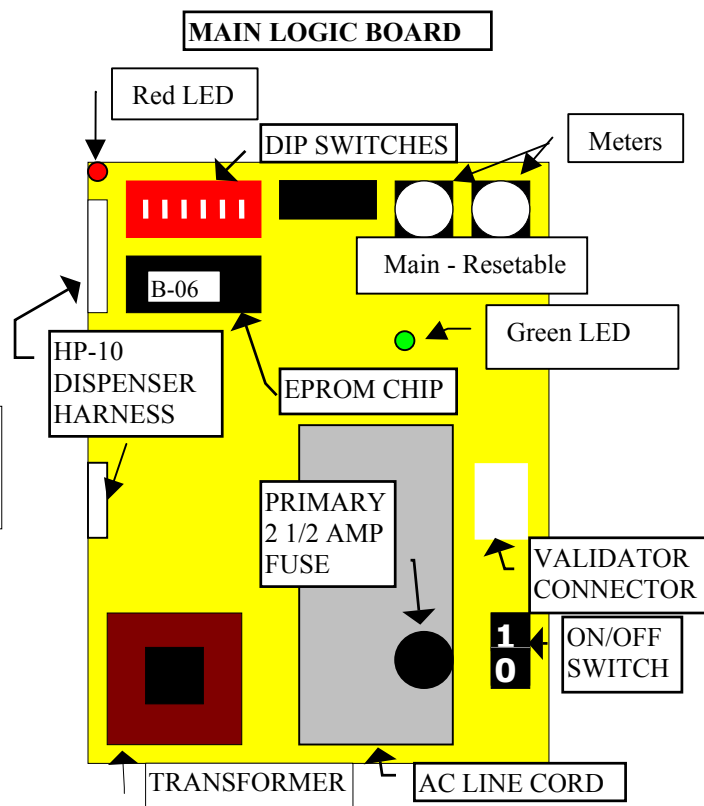

**Figure #1**

## MOUNTING THE AC7000 TO A WALL

**IF YOU ARE UNSURE IN ANY WAY IN PROCEEDING WITH THE FOLLOWING STEPS, PLEASE HIRE A LOCAL PROFESSIONAL ELECTRICIAN TO MOUNT YOUR CHANGER FOR YOU!**

1. Disconnect any and all AC power going to the series AC7000 changer. (See fig. 1)
  - A. Unplug the AC line cord from the bottom of the board.
  - B. Unplug the validator connectors on the right side of the board.
  - C. Unplug the hoppers harness connectors on the left side of the board.
  - D. Unbolt the ground wire from the right side of the cabinet.
  - E. Remove the main logic board and bill dispenser from the inside of the changer.
  - F. Put the nuts back on the studs to avoid losing the brass spacers on the studs.
2. Slide the dispenser out of the cabinet.
3. Note: You will need to verify with the building code that it is allowable to plug the changer into a 3 prong grounded outlet. If it is not, there must be 120VAC run through conduit to the changer. If it is not required, proceed to step #6.
4. Let the electrician run the conduit, install the new breaker, wire and help decide how the wiring will enter the changer (from the back or the bottom). This will affect the mounting location.

5. After the conduit has been installed, proceed with the mounting.
6. Locate the 4 punch-outs on the back wall of the changer. Using a screwdriver and hammer knock the punch-outs out by hitting them from the inside of the changer.
7. Using a stud locator, find a location to hang the changer by locating the wall studs.
8. Find an appropriate wall to bolt the changer into. The wall should have studs or be constructed of concrete. Consult a professional with any questions you may have.
9. **NOTE: HANGING THE CHANGER FROM LESS THAN ALL 4 HOLES MAY BE DANGEROUS. EACH HOLE NEEDS A BOLT THROUGH EACH ONE MOUNTED SECURELY TO THE WALL. MOUNTING THE CHANGER IN ANY OTHER WAY MAY RESULT IN THE CHANGER BEING TORN OFF OR FALLING OFF THE WALL RESULTING IN PERSONAL OR CUSTOMER INJURY ALONG WITH ELECTRICAL SHOCK.**
10. Choose a height to mount the changer keeping in mind that a handicapped person in a wheelchair should still be able to insert a bill into the bill validator. (We recommend no higher than 4 feet above the ground.)
11. Have someone hold the changer against the wall while someone else marks the holes. **CAUTION: THE CHANGER WEIGHS 125 POUNDS DO NOT EXERT YOURSELF SO THAT YOU MAY CAUSE AN INJURY.**
12. **BEFORE DRILLING THE FOUR MARKED HOLES ENSURE THAT THERE ARE NO ELECTRICAL WIRES, TELEPHONE LINES, GAS, OR WATER LINES BEHIND THE WALL WHICH DISRUPTING MAY CAUSE A LOSS OF LIFE OR PERSONAL INJURY!**
13. Hold the changer back up to the wall. Thread and tighten bolts.
14. Verify that the machine is securely mounted.
15. Reinstall the main logic board.
  - A. Before installing the main logic board, verify that the plastic safety-insulating sheet is still against the back wall where the board will be mounted and that there is a 3/8" spacer on each stud.
  - B. Install the main logic board and properly tighten the nuts.
  - C. Re-bolt the ground wire into the right side of the cabinet.
  - D. Plug the validator connector into the right side of the board.
  - E. Plug the hoppers harness connectors into the left side of the board
16. If the changer is permanently connected through a conduit, proceed to step #18.
17. Feed the AC line cord out the bottom or the back of the changer then perform the following.
  - A. Connect the AC line cord into the bottom of the main logic board.
  - B. Plug the male end into the AC wall outlet. ***Do not use an extension cord unless allowed by the building electrical code.***
  - C. **Important:** Attach the line cord clamp to the line cord. Verify it is at the right length and that the line cord is not rubbing against any sharp edges or is being strained in any way. Then mount the line cord

clamp to the studs at the hole. Tighten securely. Installation is finished and you can proceed to the "Filling the Hopper" section.

18. In order to continue you will need to purchase electrical cable conduit, a standard 3-prong AC wall outlet and 12-gauge wire. We highly recommend **HIRING** a qualified electrician to perform the following!
  - A. Install the conduit box on the conduit entering the cabinet in the lower right side of the cabinet.
  - B. Secure the 3 wires (hot, neutral, and ground) to the AC wall outlet and the ground wire should also be directly attached to the cabinet ground terminal.
  - C. Connect the AC line cord into the bottom of the main logic board.
  - D. Plug the male end into the AC outlet just installed.
  - E. Properly fold the line cord to avoid sharp corners and any other damage.
19. Proceed to the "Filling the Hoppers" section.

#### FILLING THE HP-10 DISPENSER

When the HP-10 dispenser has less than 20 bills left in it the red "Empty" LED will light on the front of the dispenser. If you have disconnected your LED or you are re-installing it, make sure the orange wire is going to the terminal on the LED that has the red wire. Whenever the "Empty" LED is "ON" the validator is disabled and it will no longer accept bills.

1. Turn OFF the power on the main logic board.
2. Slide the HP-10 dispenser out from the cabinet and open the door on the top. *There must be at least 30 bills inside HP-10 dispenser. (Somewhere between 30 and 1000 bills minimum to maximum.)*
3. Place the weight on top of the bills. The gold sheet metal on the chain connected to the dispenser has no purpose.
4. Slide the HP-10 dispenser back into the HP-10 dispenser bracket. **Do not use excessive force!**
  1. Turn "ON" the power switch. The "Empty" LED is now off and the bill validator is ready to accept bills.

#### THE DIP SWITCHES

The AC7000/7005 series dispenser is capable of dispensing \$1 or \$5 or \$10 or \$20. Setting the bills out per dollar is controlled by which Dipswitches turned "ON." (Refer to figure 1 for their location.) For example, if no dipswitches are "ON", the dispenser will pay out \$1 bills.

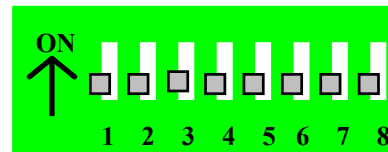

FIGURE 2  
***(THIS IS NOT THE DIPSWITCH BANK FOR SETTING THE BILL DENOMINATIONS THAT THE COINCO ACCEPTS.***  
***(For those dip switches go to page 10.)***

The following table shows how to set the dip switches to your desired pay out.

<b>"ON"</b>	<b>BILL TYPE DISPENSED</b>
NONE	\$1.00
#1	\$5.00
#2	\$10.00
#1 & #2	\$20.00

### Other Dipswitches:

The Bill Dispenser has two ways of detecting a low bill indication; automatic and manual. The automatic detect overrides the manual and is the priority detect system. It cannot be disabled. The manual detect is for those accounts that are dispensing \$1 bills and want a shut down to occur before the dispenser can absolutely NOT run out of bills. Either amount leaves 50 bills in escrow. Simply chose the amount of bills you wish to fill you hopper with EVERY time it is filled (500 or 1000). Set the dipswitches as follows:

<u>"ON"</u>	<u>BILLS ESCROWED</u>
NONE	NONE (automatic check only)
#3	500 bills
#4	1000 bills

To reset the bill counter if you have not allowed the machine to empty the bills first, press and hold down the right resettable bill meter button then the press the left. The display reads "00000" and you are ready to release both buttons and restart the machine. If the maximum count was already reach then you only press the left meter button until the board "clicks".

### FUNCTIONAL WALK-THRU FOR THE 7000

Plug the machine into a 120VAC 3-prong outlet. Decide which bills you wish to dispense and the counting mode you wish to use. Turn the On/Off switch to the "1" position and the power will cycle the bill validator and the HP-10. Press the left meter button to get your un-resettable meter count. Pressing the right meter button will give you the resettable meter count and pressing the left button while holding in the right button resets the meter. You are ready to operate the AC7000/7005.

**Error Codes:** When there is a HP-10 error the display shows the code and also the amount of bills still owed to the customer. Say the customer inserts a \$20 bill and we're dispensing \$1. The dispenser dispenses 10 \$1 bills then jams. On the display "E-42" should show then "\$10.00" notifying you that you still owe the customer \$10.

### FUSES

**High voltage fuse:** This is the primary transformer AC fuse for the main logic board and the validator. Any direct short of the Transformer or validator will cause this fuse to blow. Replace this fuse with a 2-½ amp GMA fuse only. **REPLACING THIS FUSE WITH ANYTHING OTHER THAN A 2 ½ AMP "AS" MAY RESULT IN A FIRE OR AN UNSAFE WORKING CONDITION!!** (See fig. 1 for location of this fuse.)

#### Functional Description of the Series ACAC7000/7005 Dispenser

*To follow along with this walk-through of your Bill Dispenser, fill the HP-10 dispenser with bills and turn the main logic board "ON".*

1. When power is applied the validator will cycle twice, the out-of-service LED flashes then goes out. The green LED on the main logic board comes on steady, and the red LED on the main logic board will light then go off then flicker on once per second in the standby mode. The display board lights "0000".
2. During the power-up mode the main logic board relay clicks twice enabling power (120vac) to the validator. When this relay is not enabled it routes 12vdc ground to the out-of-service LED. Without any power to the validator the dispenser cannot accept bills. Since we are

not in the error mode, the red LED on the validator logic board is on steady.

3. When a bill is inserted into the validator bill slot, the bill will be pulled inside. The validator then compares what the bill looks like to its memory. After the bill is validated it grounds the 5vdc lines causing a pulse along the yellow and blue validator harness wires to pins 5 and 15 of the main logic board. Each pulse stands for the amount of the denomination validated. (i.e. 1 pulse for \$1, 5 pulses for \$5).
4. The 5vdc pulse then travels from pins 5 and 6 to the EPROM chip (Ver. Bill A-02) pin #25. The EPROM sends a 12vdc pulse to the meter chip (U5) out pins #21 & 22 (one pulse per denomination validated). The EPROM also divides the bill pulse by the DIP switch settings (The EPROM reads the DIP switch settings during the power up mode and stores them into memory.) The display on the front of the machine is updated to the amount of the bill inserted.
5. The EPROM then sends the HP-10 dispenser pulses out pin #1 - #6 to pins 1 through 6 of the red 6-pin HP-10 dispenser plug. These pulses travel through the wires of the HP-10 dispenser wire harness to the HP-10 dispenser.
6. The HP-10 dispenser turns itself on with the first HP-10 dispenser pulse. The HP-10 dispenser counts the HP-10 dispenser pulses sent from the EPROM chip on IN3 (pin 12) while dispensing the bills at the same time. When the amount of HP-10 dispenser pulses in equals the bills dispensed through the coin counting optical sensor the HP-10 dispenser turns itself off.
7. The Dispenser returns to the standby mode with the red LED flashing once per second until another bill is inserted.

### NOTE: THE METER ON THE MAIN LOGIC BOARD CANNOT BE RESET TO ZERO!!!

#### Functional Descriptions of Out-of-Service Conditions

*Out-of-Service conditions occur for the Series AC7000/7005 dispenser for the following reasons; low bills, HP-10 dispenser fault error, validator fault, or a blown fuse.*

1. **Blown Fuse:** an AC power spike in line voltage or a bad transformer on the main logic board can cause A blown fuse on the main logic board. If either fuse blows the indication is the green LED on the main logic board will not light.
  - A. Replace the fuse. If the green LED now lights then there was a spike.
  - B. If it does not and the fuse blows again the power transformer is shorted. To test the transformer use a voltmeter set for ohms and measure across the primary (40ohms) and the secondary (1.5ohms).
2. **HP-10 dispenser Fault:** A HP-10 dispenser fault can either be a jammed HP-10 dispenser, a blocked bill counting optic or a bad HP-10 dispenser logic board.
  1. An indication for a jammed HP-10 dispenser is an error code displayed on the front of the machine. This code will have the following format, "E-31". ***If the customer did not receive his full allotment of bills the format is Error code then amount owed.***
  2. At this point the three options open are to attempt repair on your own, call your

distributor, or return the HP-10 dispenser to American Dispenser.

3. **Validator Fault:** When a validator fault occurs the validator's EPROM shuts down the validator and flashes an error code via the red LED on the validator logic board. When there is no error this LED is on steady. The validator only gives bill pulses to the main logic board so the main board never knows if the validator isn't functioning. Therefore the out-of-service-LED will not light. (See page for validator error codes.)

1. **Low Bills:** The low bill condition is probably the most common fault. The EPROM on the main logic board is constantly checking for low bills in the HP-10 dispenser. If the display board is flashing all zeros and the empty LED is lit then there is a low bill condition. Place more bills into the bill box and press the LEFT meter switch and this will reset the Empty condition. (It also resets the manual bill counter if you have one of these dipswitches turned "ON".)

#### Indicator Lights

##### Main Logic Board:

1. Green LED on: AC power applied to the logic board. All fuses are good.
2. Red LED
  - A. Heartbeat - 5 and 12vdc present. The dispenser is in standby waiting for a bill pulse.
  - B. On Steady - Out of service, HP-10 dispenser error detected.

##### Validator logic board:

1. Red LED
  - A. On Steady - Standby Mode, waiting for bill insertion.

- B. Flashing - Error mode, go to page for error code information.
- C. Off - The dispenser "Empty" LED is lit.

#### WIRE HARNESS COLOR AND DEFINITIONS

##### Validator harness:

- Red - Switched Hot 120VAC.
- White - Neutral 120VAC.
- Black - 120VAC Low current validator enable.
- Yellow - +5vdc credit pulse line.
- Blue - -5vdc credit pulse line.
- Orange - +12vdc Empty LED.
- Brown - -12vdc Empty LED.

##### CoinCo BA30 Flash Codes

Flash codes 1-6 may appear during normal servicing of the BA30. To access flash codes 7-18; open bill box lid and remove power from the BA30 for 10 seconds. Reapply power to BA30 with bill box lid open. Flash codes 7-18 will now appear for respective error or condition detected in the BA30. If more than one error or condition exists, the lower number flash code will appear until its respective error or condition is corrected. The left and right sensors referenced below are given viewing the BA30 from the front.

# Of Flashes	Description of Flash Codes
1	Bill box full
2	Bill box lid is open or bill box is off
3	Check bill path
4	All bill accept switches are off
5	Bill jam or sensor error
6	Stacker motor/home sensor
7	Transport motor/encoder sensor

For higher error codes or any other service problems call our service department toll free at:

**(888) 741-9840**

**CASH CODE USERS**

If you are accepting \$50 and \$100 bills then you are using the Cash Code bill validator. Here is the information for that unit.

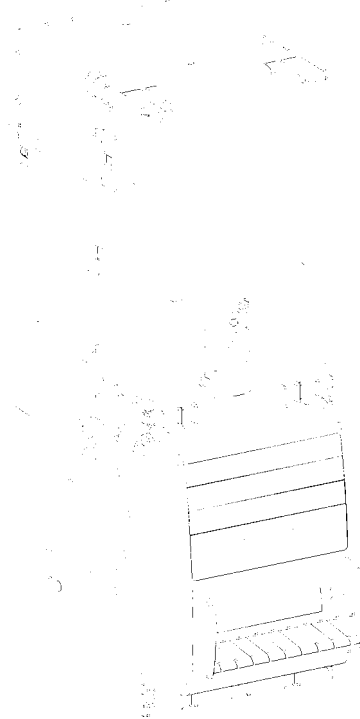

USA (us for)	1	2	3	4	5	6	7	8	1	2	3	4
4 PULSE/\$1	OFF	OFF	ENABLE		ONE WAY UP	DOWN STACKER	FAST SLOW PULSE	ISOLATED INTERPACES	ENABLE		HIGH SECURITY	BDP OFF
3 PULSE/\$1	ON	OFF	\$1	\$5					\$50			
2 PULSE/\$1	OFF	ON			FOUR WAY DOWN	STACKER	FAST SLOW PULSE	ISOLATED INTERPACES	DISABLE		HIGH SECURITY	BDP ON
1 PULSE/\$1	ON	ON	DISABLE						DISABLE			

**Diagnostics**

If the red light on the front of the bill validator is ON insert bill and remove it after the red light goes OFF. Count the number of red flashes and compare with the diagnostic chart below.

#		#	
1	Cassette is removed from bill validator	7	Failure of magnetic sensors
2	Stacking motor does not rotate	8	Transporting motor does not rotate
3	Cassette is full	9	Speed of transporting motor is too fast
4	Mechanical jam in cassette (stacking motor can not stack the bill)	10	Transporting motor electrical overload
5	Stacking motor electrical overload	11	Bill pathway security latch is open
6	Failure of optical sensors	12	Banknote is in the entry slot of the cassette and credits were not issued

Notes:

- If the bill was inserted but the red light on the front of the bill validator did not go OFF there is a failure in communication.
- When diagnostics is completed the red light becomes steady again. Do not consider it like a flash and do not count it.

### 5. Electrical Specification

Operating Voltage	Maximum Operating Current	Maximum Current (t<2sec)
10...14 V DC	0.85 A DC	2.2 A DC

- Use current limiting Power Supply only

# MAG BILL ACCEPTOR

Operation and Service Manual



## COINCO MAG50B VALIDATOR SECTION



	PAGE
Removing the Bill Box	9
Clearing a bill jam	9
Setting the bill types accepted	10
Cleaning the sensors	11
Cleaning a salted unit	12
Replacing the belts	13





### Removing the bill box.

To remove the 1000 bill stacker from the CoinCo validator follow the picture below.

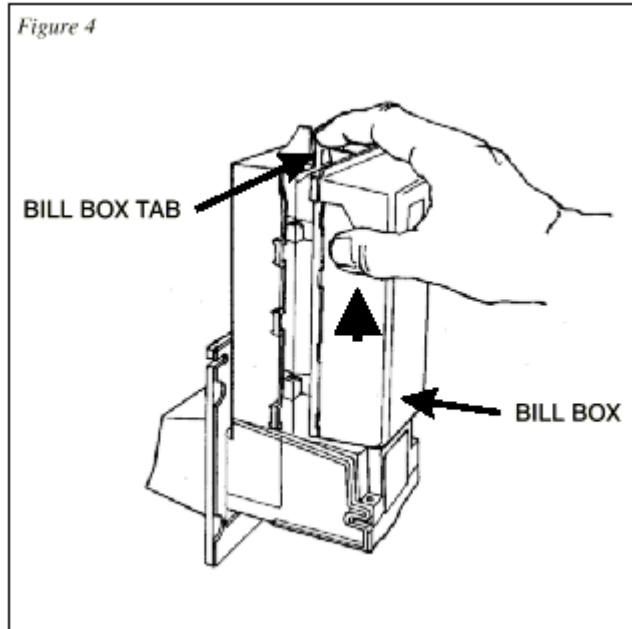

### REMOVING A BILL JAM

From time to time a foreign object or ripped bill will become caught in the validator. Follow the picture below to remove the item.

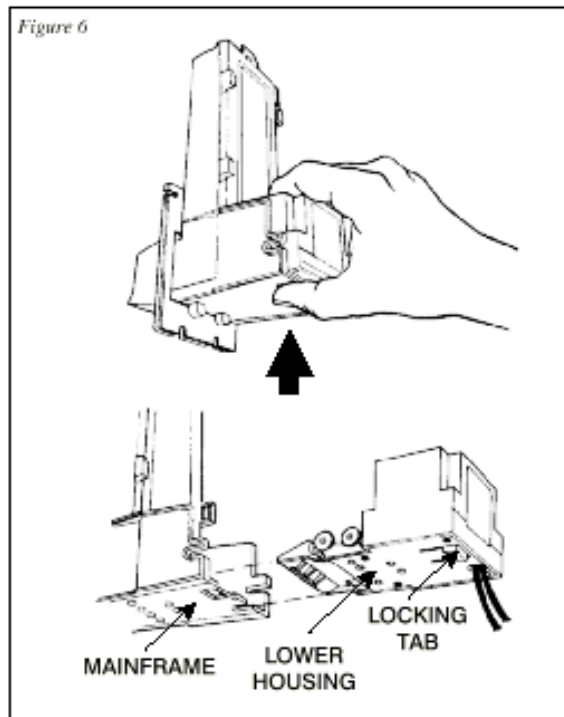

## SETTING THE BILL ACCEPT DIP SWITCHES

*Figure 1*

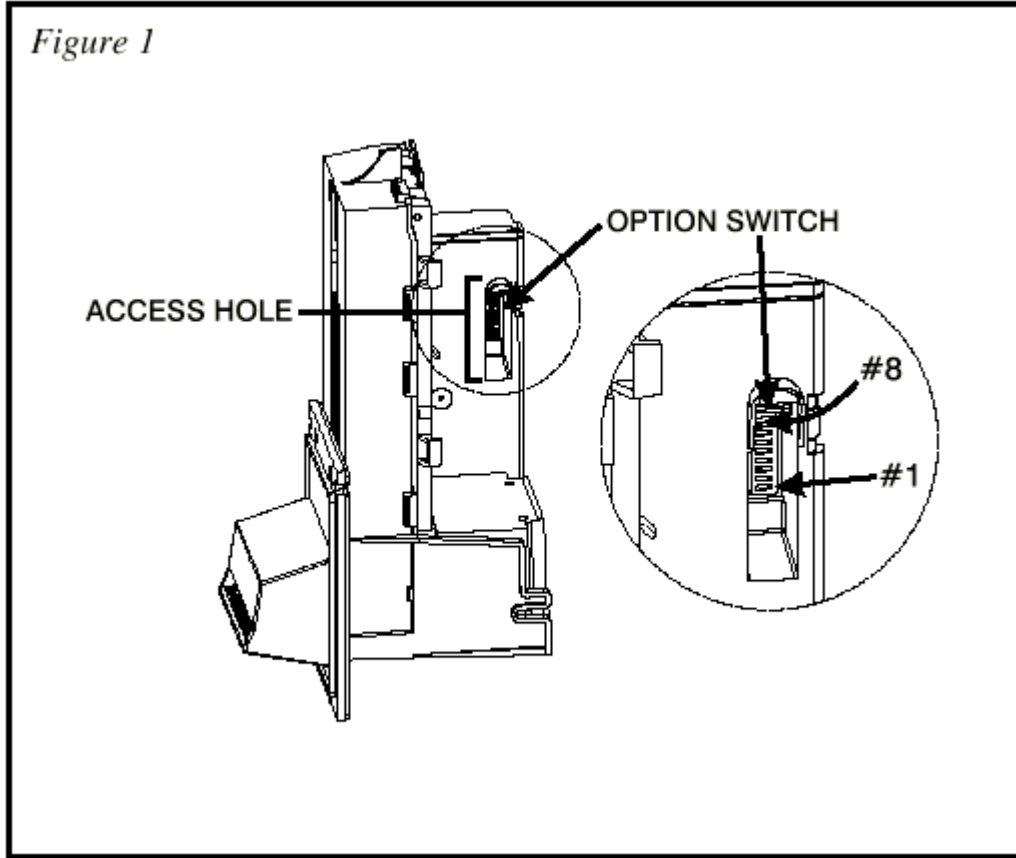

*Figure 2*

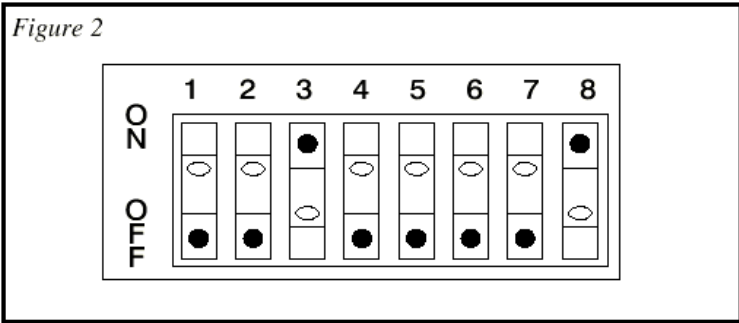

SWITCH	ON	0
1	High Security	Standard Acceptance
2	Accepts bills in one directions only (face up, green seal first)	Accepts bills in both directions (face up)
3	Serial or Parallel Interface	Pulse Interface
4	\$20 Accept	\$20 Reject
5	\$10 Accept	\$10 Reject
6	\$5 Accept	\$5 Reject
7	\$2 Accept	\$2 Reject
8	\$1 Accept	\$1 Reject

## CLEANING THE BILL VALIDATOR

Refer to the pictures and the procedure on the next page to clean the bill validator every 4-6 months.

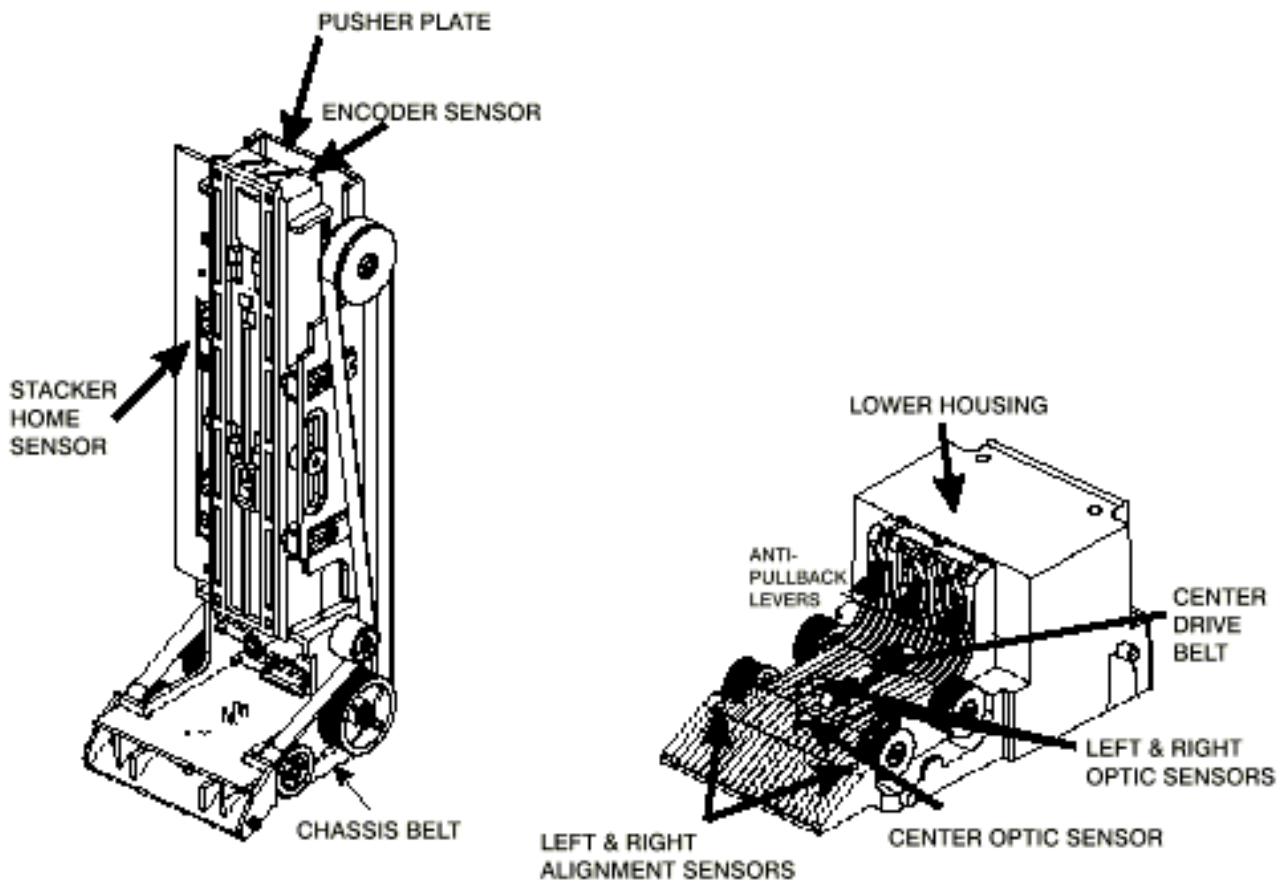

**BA30B (B) CLEANING IF ANY OF THESE PROCEDURES ARE PERFORMED TO YOUR VALIDATOR AFTER IT IS RETURNED UNDER A WARRANTY REPLACEMENT, YOU WILL BE SUBJECTED TO A \$35.00 LABOR FEE.**

**BA30B CLEANING AND MAINTENANCE:**

**Note:** Petroleum-based cleaners and freon-based propellants can damage plastic and some electronic components. Scouring pads and stiff brushes may harm the protective conformal coating on the circuit boards and can mar the plastic. These items should never be used when cleaning the BA30 bill acceptor.

**The BA30 should be cleaned every 7,000 bills or every 4 -6 months (or as needed, depending on the environmental conditions of the location). Dust can be removed with a soft brush or cloth or it can be blown out using compressed air.**

**Procedure:**

1. Disconnect power from the bill acceptor.
2. Remove the bill box and use a soft cloth to wipe the dust from around the intermediate frame and stacker plate.
3. Remove the lower track.
4. Using compressed air or a soft brush, blow or brush the dust off of the optic sensors and out of the recessed sensor openings.
5. Remove dust from around the belts and wheels on the lower housing and the sensors on the upper sensor board. The upper sensors are located directly above the lower housing sensor when the lower housing is installed.
6. The bill path can be cleaned to remove further dirt and oil using a soft cloth moistened with a mild soap and water solution.
7. Clean the magnetic head using a swab and isopropyl alcohol.
8. Once the lower housing is dry, place it back into the mainframe so that the tab on the bottom locks into place.
9. Blow the dust out of the encoder wheel and its sensors. (It may be necessary to extend the stacker plate to access the encoder wheel. Supplying power to the unit momentarily can do this, so that the stacker plate extends.)
10. Remove dust from the transport belt areas and from any other places of build up.
11. Remount the bill box.
12. Apply power and insert bills to verify that the unit is functioning properly.

**BA30 CLEANING PROCEDURE FOR SALT WATER POLLUTED UNITS:**

**Note:** Petroleum-based cleaners and freon-based propellants can damage plastic and some electronic components. Scouring pads and stiff brushes may harm the protective conformal coating on the circuit boards and can mar the plastic. These items should never be used when cleaning the BA30 bill acceptor.

**Procedure:**

1. Remove power from the bill acceptor.
2. Remove the bill acceptor from the vending machine.
3. Open the bill box lid and verify that the stacker plate is in the stand-by/home position. If it is not in the home position, apply power and observe that the stacker plate returns home.

**Warning:** If moisture is present, allow the unit to dry thoroughly before applying power to avoid possible shock hazard. If the stacker plate does not return to the home position, remove power and carefully remove the bill box to avoid damaging the bill box and/or stacker plate.

4. Remove the lower housing.
5. Remove the bottom cover from the lower housing.
6. Run hot water (1101/4-1401/4F) over the lower housing from the top and bottom. Using a soft brush, gently clean any residual salt. Use a soft absorbent cloth to clean any residue off the lower housing. If the transformer gets wet, allow the unit to dry for 24 hours before applying power.
7. Remove the front mask. Using hot water and a soft brush, clean the front mask, upper sensor board, main frame anti-pullback levers and position sensor mount.

*Caution: The motors are not protected from water, therefore the unit must be held in a manner that prevents water from running over the intermediate frame crossbar.*

*8. Remove the position sensor cover on the crossbar and carefully lift the LED from its mount. (Early models only.)*

*Caution: Protective coating on the LED leads should not be damaged. Clean all salt residue from the mount, sensor hole and detector area.*

*The detector can be seen through the sensor hole, and is located in the chassis. Replace the position sensor cover. (Early models only.)*

9. Verify that the anti-pullback levers move freely and that the spring returns them to their open position.
10. Allow the unit to dry thoroughly.
11. Clean the magnetic head using a swab and isopropyl alcohol.
12. Replace the front mask
13. Replace the lower housing cover.
14. Replace the lower housing into the main frame.
15. Remount the bill box.
16. Apply power and insert bills to verify that the unit is functioning properly.

**6 OR 7 ERROR CODE FLASHES**

*The cleaning procedure for this common occurrence is listed below. Just follow these steps.*

1. If this code has occurred on a new machine or one that the validators DIP switches were just changed, Ensure that all the white plugs on the side of the validator board away from the red LED are plugged in securely.
2. Remove the bill box.
3. Turn the PayStation ON then OFF in an attempt to stop the metal push plate so that it COASTS into the fully outward position.
4. Using an air compressor or a can of compressed air blow out the area behind the push plate until it is completely free of all dust and lint.
5. Turn the PayStation power back on so that the push plate returns to the inward position. If the same error code persists, repeat steps 1 - 3 concentrating on the top center area behind the plate.
6. Replace the bill box.

7.

## REPLACING THE BELTS

Every 2-3 years the belts on the CoinCo will wear out. To replace them, remove the validator components down to the picture show. Refer to the parts diagram at the end of the manual for help getting to this point.

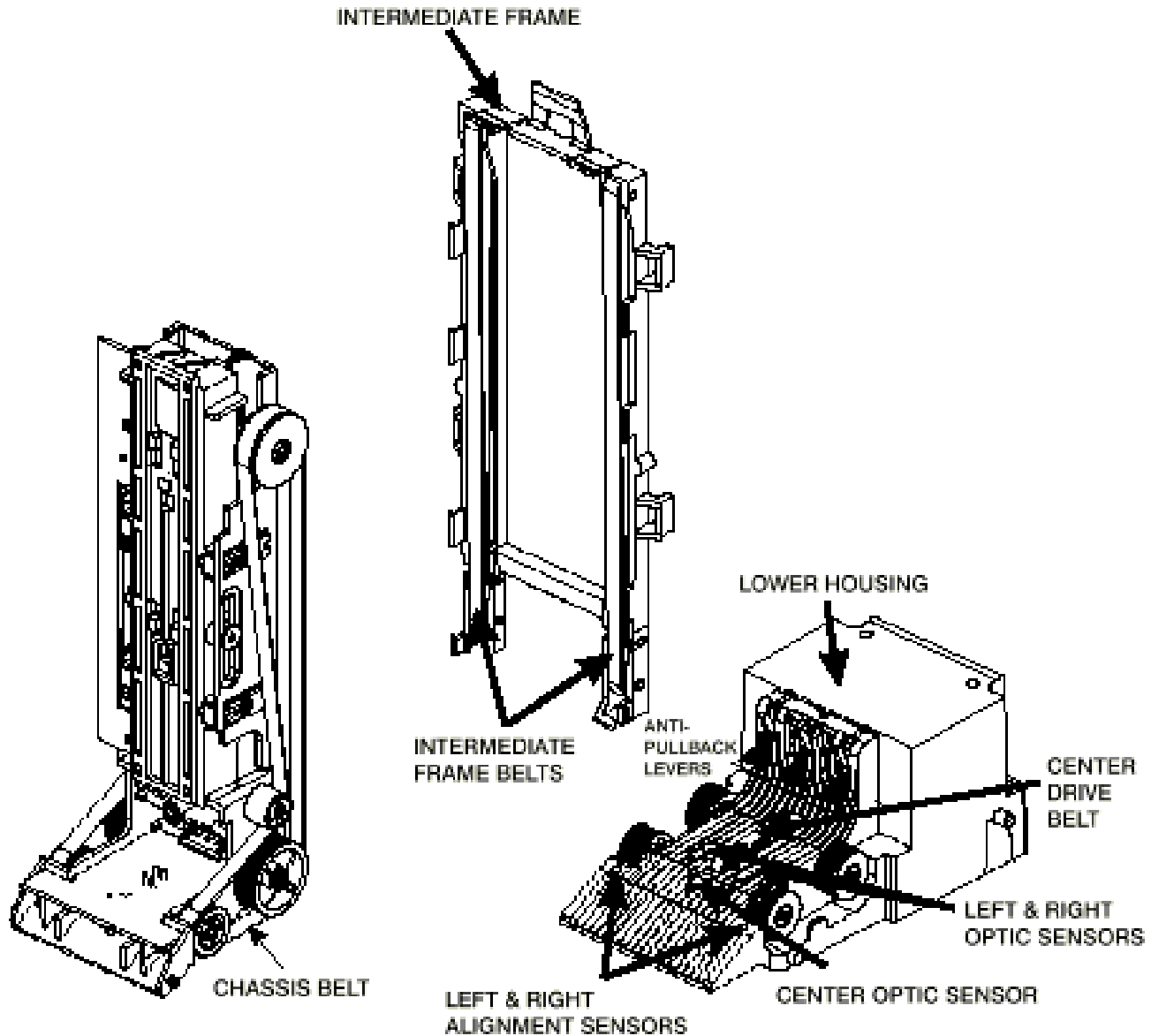

JCM'S  
HP-10  
BILL DISPENSER  
OPERATIONS  
AND  
TROUBLESHOOTING  
PROCEDURES

**Cleaning and maintenance...15-16**

**Adjustments.....17**

**Error Code Definitions.....18-20**

**Test Procedures.....21-27**

## Cleaning and Maintenance

### Rubber parts Cleaning.

- 3-1) Clean approximately once/week or as needed.
- 3-2) Clean with cotton dipped in a 50% diluted methanol solution.
- 3-3) Turn rollers as needed. There is no certain home position to return to. The stop roller turns only one way. Please do not force it the wrong way.

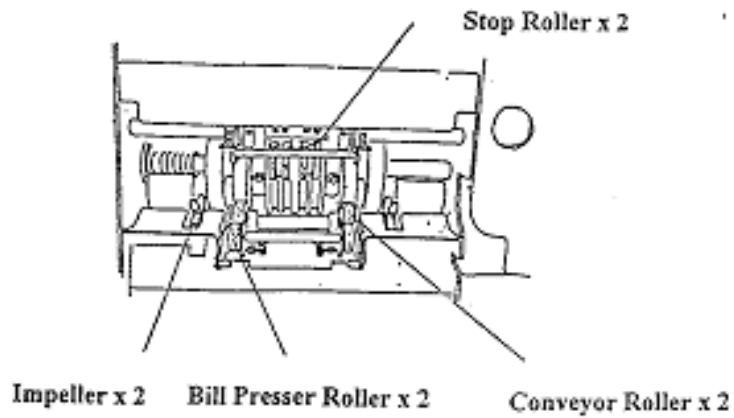
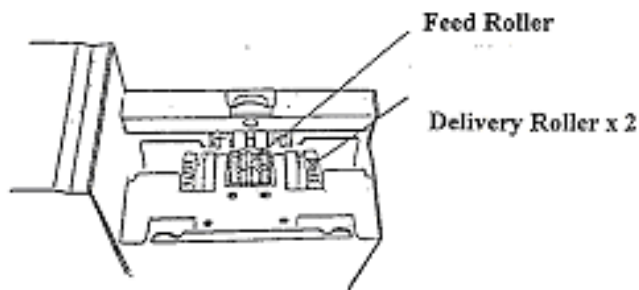



4. Sensor Cleaning.

- 4-1) Clean approximately once/week or as needed.
- 4-2) Blow sensors off with air.
- 4-3) Sensor locations are shown below.

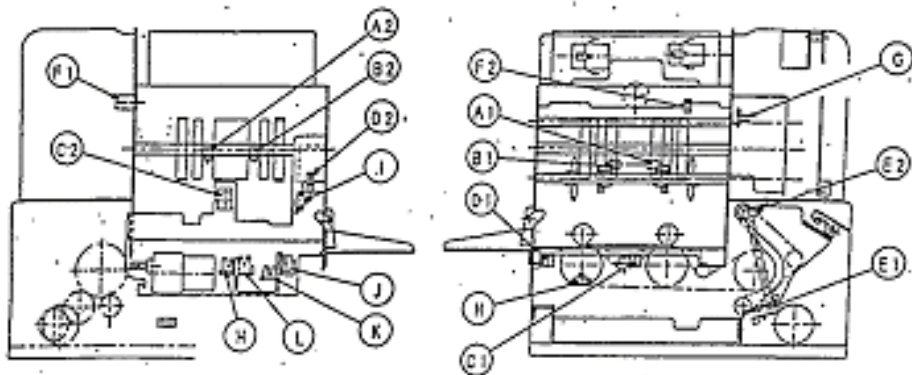

Label	Sensor Name	Label	Sensor Name
A	Counting Sensor (Right)	H	Pay out Timing Sensor
B	Counting Sensor (Left)	I	Shutter Sensor
C	Stacker Remain Sensor	J	Bill Presser Sensor (Up)
D	Outlet Remain Sensor	K	Bill Presser Sensor (Down)
E	Rejects Conveying Sensor	L	Table Position Sensor (Up)
F	Near End Sensor	M	Table Position Sensor (Down)
G	Timing Pulse Sensor		

4-4) Accessing the counting sensors for cleaning. Open the top feed path door by lifting the green bar. These sensor locations are shown below.

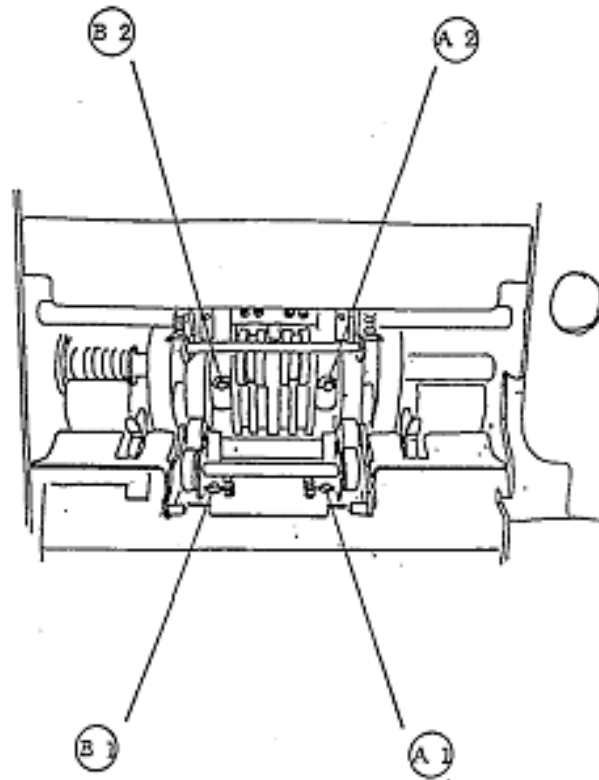

## 9. Error information

### 9.1 System error

Error code	Item	Contents
E-01	Timer error	CPU built-in timer is abnormal
E-02	ROM error	ROM data is abnormal
E-03	RAM error	RAM is abnormal

### 9.2 Conveying unit

Error code	Item	Contents
E-10	Sensor level error	Level of counting sensor R is not within specified values
E-11	Sensor level error	Level of counting sensor L is not within specified values
E-12	Long bill error	Bill length is longer than specified value
E-13	Short bill error	Bill length is shorter than specified value
E-14	Double fed bill error	Double feeding of bills detected
E-15	Overrun error	More than specified number of bills counted
E-16	Bill jam error	Bills jammed at conveying section
E-17	Main motor locked	Locking of main motor detected
E-18	Abnormal emitted light	Abnormal amount of light emission by counting sensor detected

### 9.3 Actuator position

Error code	Item	Contents
E-20	Bill presser error 1	Bill presser unit could not be set
E-21	Bill presser error 2	Two bill presser position sensors switched off at the same time
E-22	Table error 1	Table unit could not be set
E-23	Table error 2	Two table position sensors switched off at the same time
E-24	Shutter error	Shutter operation faulty

### 9.4 Dispensing unit

Error code	Item	Contents
E-30	Bill remaining error	Bill left remaining in temporary retaining section
E-31	Bill jammed error	Bills jammed at reject section
E-32	Dispensing motor locking	Locking of dispensing motor detected

### 9.5 Others

Error code	Item	Contents
E-40	Command error	Commands other than normal received
E-41	Excessive demand error	Demand for 11 bills or more made
E-42	Short count error	Specified number of bills not dispensed
E-43	Bills left at outlet	Count command received with bills remaining in outlet

### 9.6 Error resetting method

- (1) E - 01 ~ E - 03      Change substrate
- (2) E - 12 ~ E - 14      Reset initial command  
(Re-try maximum 3 times)
- (3) E - 40 ~ E - 42      Automatic resetting
- (4) E43                    Automatic resetting. Command receivable condition set by removing bills from outlet
- (4) Others                Reset initial command



## 12.2 Test mode

This mode is for making dispensing test independently by this unit; on operation tests relating to respective sensors, actuators, display of internal data, and setting of station addresses.

### (1) Sensor check

Starting can be made by switching on power with the DIP switch bit 8 switched on. In this mode, checking of sensor operation of sensors other than the count sensor and encoder sensor (main motor, conveying motor) can be made.

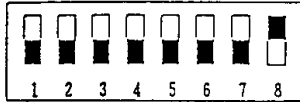

After switching on power, checking can be made by having each sensor coping with respective segments. Also, by pressing test switch 2, positions of the bill presser and table can be changed.

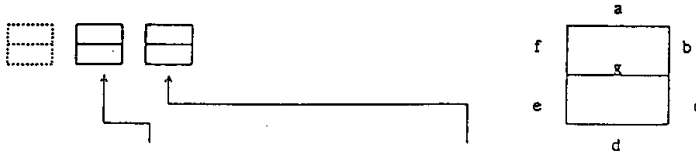

- a : Conveying of rejects
- b : Temporary retaining section bills remaining
- c : Bill presser (up)
- d : Bill presser (down)
- e : Table (up)
- f : Table (down)
- g : Shutter
- d.p. : Outlet bills remaining
- Hopper near end

By pressing test switch 1, the uppermost column show changes as indicated below and individual sensor conditions are displayed.

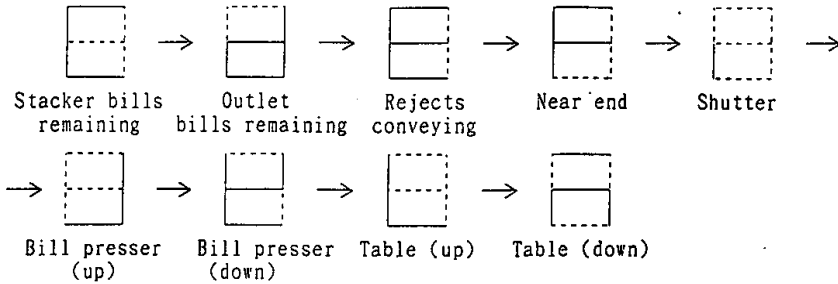

Condition of individual sensors, "0" displayed with light doused between optical axes and "1" displayed with light passed

(2) Dispensing test

Can be started by turning on the power with DIP switch bit 1.8 in ON condition. After completion of initial operation, the following operations can be performed by setting DIP switches.

• Manual dispensing

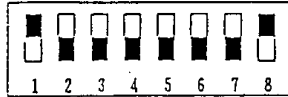

Counting and dispensing operations can be performed by pressing DIP switch 1 or 2.

• Continuous dispensing

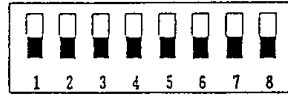

Operation started by pressing DIP switch 1 or 2. Operation interrupted by setting to others.

When an outlet tray is fitted, there are cases where normal operation may not be made.

• Reject operation

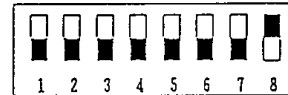

Counting, rejecting operation is made by pressing DIP switch 1 or 2.

• Setting of number of bills to be dispensed

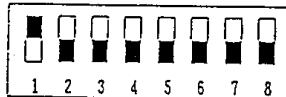

By pressing DIP switch 1, 1 bill is added to the set number of bills.

By pressing DIP switch 2, 1 bill is subtracted from the set number of bills.

When an error occurs, removing the cause of error and pressing test switch 1 or 2 releases the condition.

(3) Counting sensor adjustment

Starting is made by switching on the power with the DIP switch Bit 2. 8 in an ON condition. When DIP switch 1 is pressed after starting, the following changes are made.

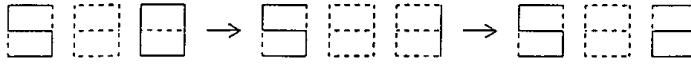

• Error log clearing

In a "S 4" condition, press test switch 2 to clear error log inside memory.

• Clearing of data on total counted number of bills

In a "S 5" condition, press test switch 2 to clear data on total counted number of bills in the memory.

• Right side counting sensor level display

In a "S 0" condition, press test switch 2 to display the level of the right side counter sensor.

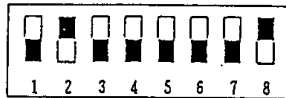

By pressing test switch 2 in this condition, the light emission data of the right side counting sensor is displayed.

• Left side counting sensor level display

By switching off DIP switch Bit 8, the sensor level of the left side counting sensor is displayed.

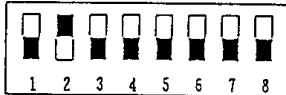

By pressing test switch 2 in this condition, the light emission data of the left side counting sensor is displayed.



(4) Actuator check

By turning on the power with the DIP switch Bit 3.8 in an ON condition, starting can be made. By setting the DIP switch after starting, the following operations can be made.

• Main motor check



By pressing test switch 1, regular rotation operation is made for about 3 seconds. The encoder sensor can also be checked in this mode.

• Dispensing motor check

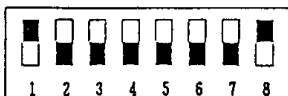

By pressing test switch 1, motor rotates for approximately 3 seconds in the dispensing direction.

The encoder sensor can also be checked in this mode.

• Table motor check

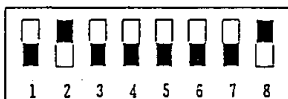

By pressing test switch 1, the table unit is moved to the upper side position. By pressing test switch 2, the table unit is moved to the lower side position.

• Bill presser motor check

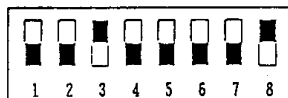

By pressing test switch 1, the bill presser unit is moved to the upper side position. By pressing test switch 2, the bill presser unit is moved to the lower side position.

• Shutter check



By pressing test switch 1, shutter opening operation is performed. By pressing test switch 2, shutter closing operation is performed.

• Clutch check

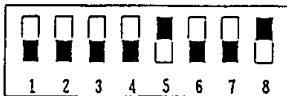

By pressing test switch 1, the main motor is run in the regular direction for about 3 seconds with the clutch engaged.

The bill intaking related mechanism rotates. (rubber lined roller)

The respective modes excluding the shutter check, makes all concerned sensors effective. (Including the encoder sensor of the main motor and conveying motor.)

(5) Ageing

By switching on the power with the DIP switch bit 5.8 on, starting is made. By pressing test switch 1 or 2 after starting, ageing is started.

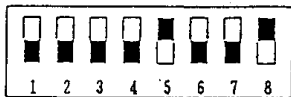

(6) Internal data display

By switching on the power with DIP switch bit 6.8 on, starting is made. By setting the DIP switch after starting, the following operations can be made.

• Error log display

The highest level columns are displayed "A", "B", "C"--- and the error occurrence total is displayed in decimal figures in the two lowest columns. The highest displayed value is "99" and even when values become 100 and higher, "99" is

displayed. By pressing test switch 1, the displayed contents changes in the order of "A", "B", "C"--- and by pressing test switch 2, changes in the order of "E", "D", "C" -----.

A : E-10	I : E-18	Q : E-32
B : E-11	J : E-20	R : E-40
C : E-12	K : E-21	S : E-41
D : E-13	L : E-22	T : E-42
E : E-14	M : E-23	U : E-43
F : E-15	N : E-24	
G : E-16	O : E-30	
H : E-17	P : E-31	

Error occurrence data can be cleared by starting the sensor check mode and pressing test switch 2 while in "S 4" condition.

• Internal data display

The highest level columns display "1", "2", "3",-----and the lowest 2 columns display respective data in HEX values.

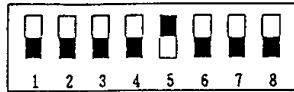

By pressing test switch 1, the displayed contents change in the order of "0", "1", "2", and by pressing test switch 2, change in the order of "4", "3", "2"----

- 0 : Total counted number of bills ( Upper level columns)
- 1 : Total counted number of bills ( Lower level columns)
- 2 : Right side counting sensor emission volume initial value
- 3 : Right side counting sensor emission volume
- 6 : Left side counting sensor emission volume initial value
- 7 : Left side counting sensor emission volume

Others are designing data

The total counted number of bills are displayed approximately in units of 100 bills.

Example    000 }  
                   10E } 14 x 100 = 1400

(7) Adjustment of dispensed bill quantity

Starting is made by switching on power with DIP switch bit 7.8 on.

In this mode, the quantity of dispensed bills can be adjusted in units of approximately 7 mm. By pressing test switch 1, 1 value is added and by pressing test switch 2, 1 value is subtracted.



After setting the value, writing into memory is made by turning off the DIP switch bit 8.

(8) Setting of station address

By switching on power with the DIP switch bits 1, 2, 3 and 4, 8 on, starting is made.

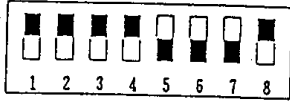

Setting procedures

- ① By the 4 lower level columns of the DIP switches, settings to 00~0F values are made.
- ② DIP switch data is displayed by pressing test switch 1.
- ③ Data before change is displayed by pressing test switch 2.
- ④ Data after changing is written into memory by pressing test switch 1 again.
- ⑤ By further pressing test switch 2, writing of data into memory after change is confirmed.

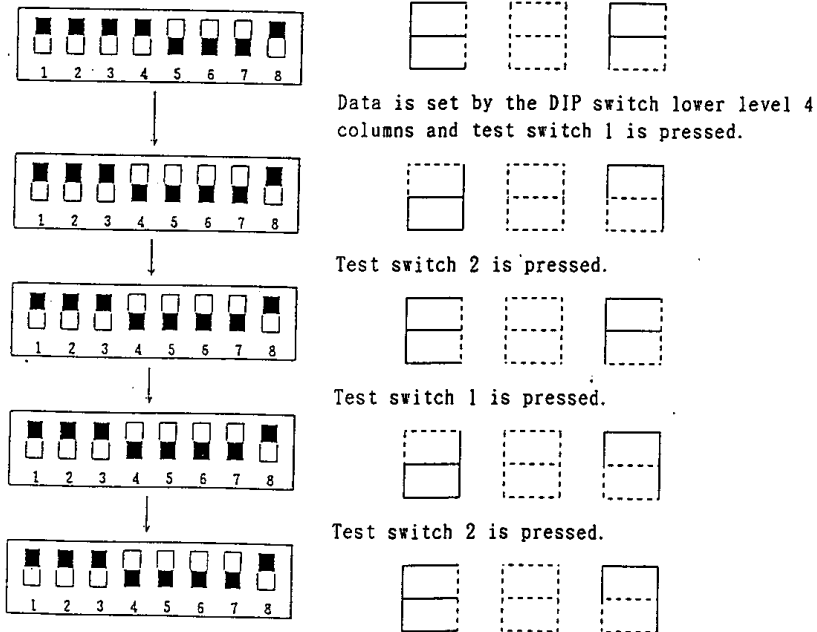

Setting completed

# TROUBLESHOOTING GUIDE

**TO USE THE TROUBLESHOOTING GUIDE, MATCH UP THE PROBLEM, THEN FOLLOW THE SOLUTION SUGGESTIONS. After every step re-try operating the changer to see if the problem has been solved.**

<i><b>PROBLEM:</b></i>	<i><b>SOLUTION:</b></i>
A. The bill validator pulls in the bill slightly then rejects it.	<ol style="list-style-type: none"> <li>1. Clean the validator. (pg. 9)</li> <li>2. Remove the lower housing (pg. 11) of the bill validator. Ensure the center wheel spins freely. Push straight down on it slightly to loosen.</li> </ol>
B. The bill validator red status LED flashes a "5" error code.	<ol style="list-style-type: none"> <li>1. Clean the validator optic LED's. (See pg. 9)</li> <li>2. Ensure that all the wire harness plugs are plugged firmly into their white female sockets.</li> <li>3. Turn to the back page of this manual and check for a Coin Acceptors branch in your area to repair your bill validator.</li> </ol>
C. The bill validator red status LED flashes a "6 or 7" error code.	<ol style="list-style-type: none"> <li>1. Take the bill stacker off the bill validator. Cycle the power on / off using the switch on the main logic board and coast the silver push bar so that it stops in its fully extended position. Blow out the area behind the push bar with high pressure or canned air. Concentrate on the encoder wheel in the area top center behind the push bar.</li> <li>2. Turn to the back page of this manual and check for a Coin Acceptors branch in your area to repair your bill validator.</li> </ol>
D. The bill validators red status LED is on steady but it still will not accept the bill.	<ol style="list-style-type: none"> <li>1. Pull out the lower housing, see page, and look for something obstructing the bill path. (I.e. gum, paper, tickets, coins, etc.)</li> <li>2. Look inside the Plexiglas case on the side of the bill validator. Ensure that all the wire harness plugs are plugged firmly into their white female sockets.</li> </ol>
E. Red LED display on the side of the bill dispenser reads "E18".	<ol style="list-style-type: none"> <li>1. The flap where the bills are counted has fallen open.</li> <li>2. Lift the flap up and push until it snaps shut.</li> </ol>
F. Red LED display on the side of the bill dispenser reads "E22".	<ol style="list-style-type: none"> <li>1. The left side of the bill support bracket is rubbing against the final bill dispense shelf. The shelf cannot lower to the final dispense level.</li> <li>2. Insert 2 washers between the bill support bracket and the bill dispenser body, or grind down the left bill support bracket tab.</li> </ol>
G. Red LED display on the side of the bill dispenser reads "E31".	<ol style="list-style-type: none"> <li>1. The motor release in the back of the dispenser where the wire harness plugs into the bill dispenser has fallen open. Look for the green lever and lift the motor to its dispense position.</li> </ol>

## COINCO PARTS LIST

### **MOUNTING ASSEMBLY PARTS BREAKDOWN**

ITEM NO.	PART NO.	DESCRIPTION
1	438-6	Nut & Lockwasher
2	922015	Snack Mask
3	921401	Screw
4	921492	Mounting rame
5	920807-2	Main rame
6	921357	Grounding Spring
7	345-6R6	Screw
8	902224	24 VOLTS Decal

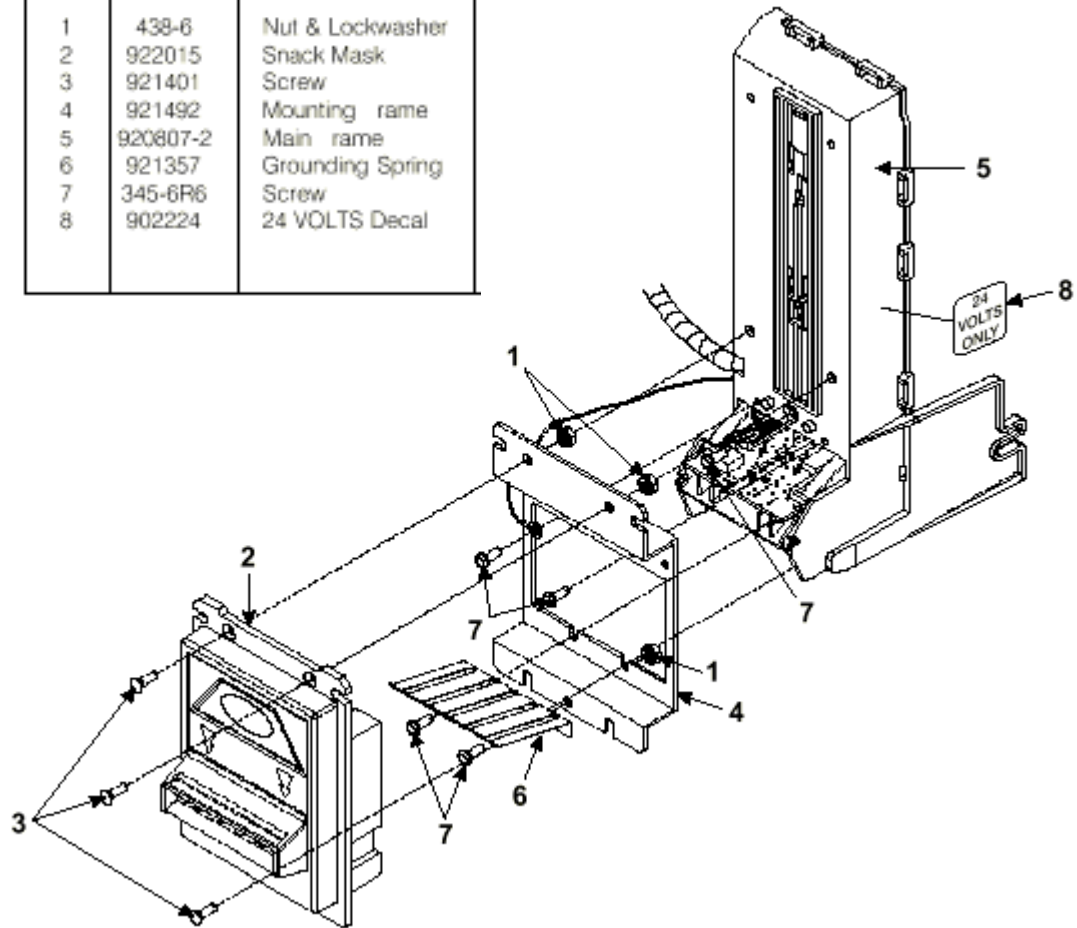

## COINCO PARTS BREAKDOWN

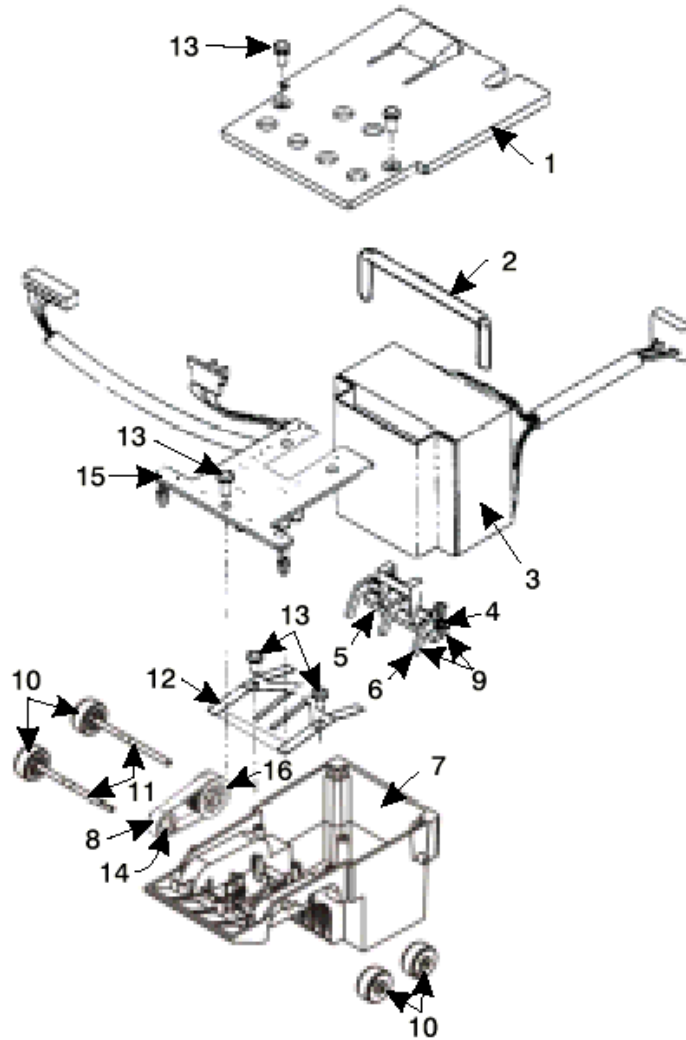

ITEM NO.	PART NO.	DESCRIPTION
1	921704	Bottom Cover
2	921613	Transformer Holding Hose
3	921798-1	MAG50B Transformer & Shield
4	920889	Anti-Pullback Lever Spring
5	920819-1	Anti-Pullback Lever Mount
6	920818	Anti-Pullback Lever
7	407977	Lower Housing & Lens Assy.
8	923403	Center Belt
9	407936	Anti-Pullback Lever & Mount Assy.
10	408165-1	Pulley and Tire Assy.
11	923080	Drive Shaft
12	923102	Mag Spring
13	345-4R4	Screw, #4 x 1/4 PH Plastite
14	923101	Idler Roller
15	407245-18	Lower Sensor Board
16	408056	Pulley and Hub Assy.
17	906303	Cable Tie

## COINCO PARTS BREAKDOWN

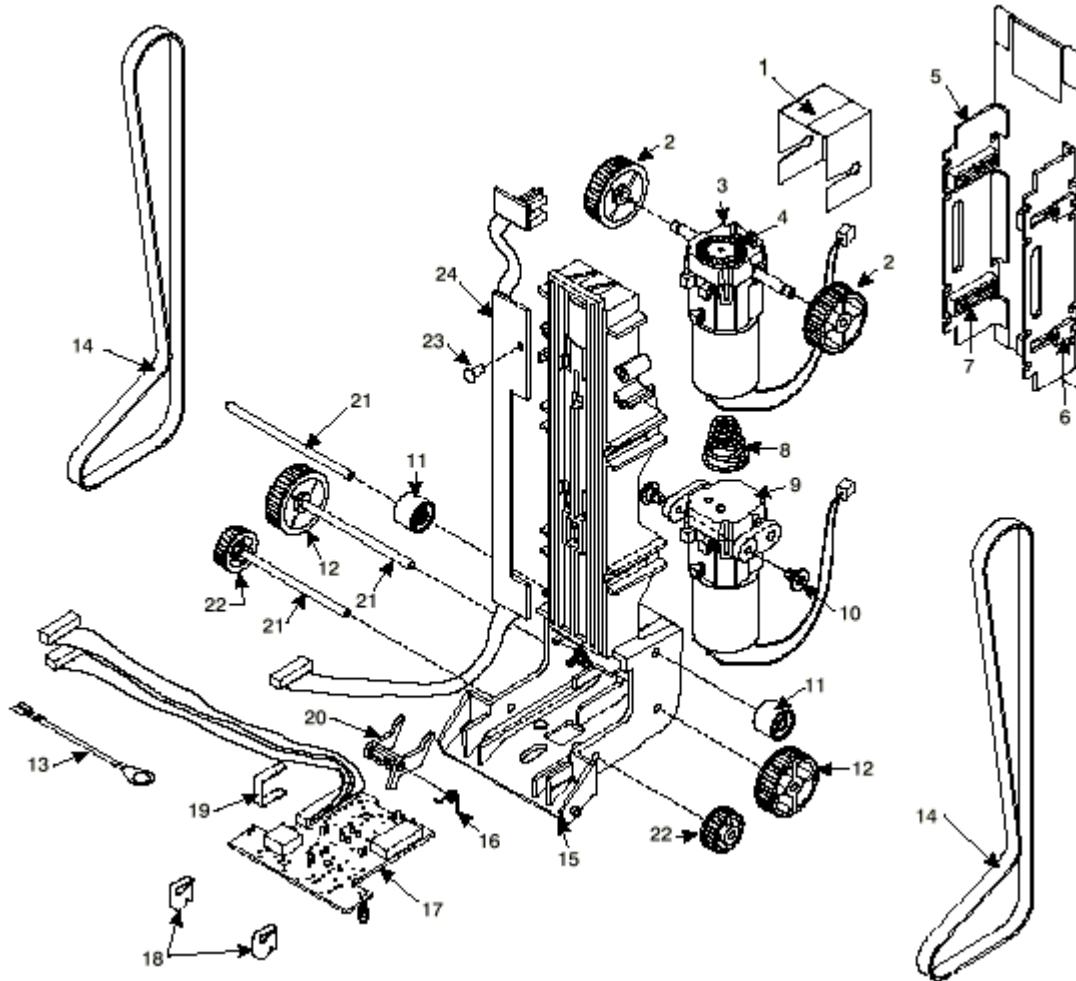

ITEM NO.	PART NO.	DESCRIPTION
1	923770	Dust Cover
2	408054	Upper Transport Pulley & Hub Assy.
3	407254-1	Transport Motor Gearbox Assy
4	920000-3	Encoder Wheel
5	407952	Plastic Stacker Pushplate Assy.
6	920836	Stacker Cap
7	920833-1	Stacker Slide
8	921387	Belt Tension Spring
9	407253-1	Stacker Motor Gearbox Assy.
10	920834-1	Pushplate Bearing Screw
11	920829-1	Idler Pulley
12	408055	Lower Transport Pulley & Hub Assy.
13	407454	Ground Wire
14	921403	Chassis Belt
15	407974	Chassis & Lens Assy.
16	920889	Anti-Pullback Spring
17	407244-10	Upper Sensor Board
18	920827	Upper Board Clip
19	921128	Wire Clip
20	920828-1	Anti-Pullback Lever
21	920040	Pulley Shaft
22	408057	Inlet Pulley & Hub Assy.
23	345-4R4	Screw
24	408031	Stacker Board
25	901358	4" Cable Tie
26	407796	Lens Kit



## COINCO PARTS BREAKDOWN

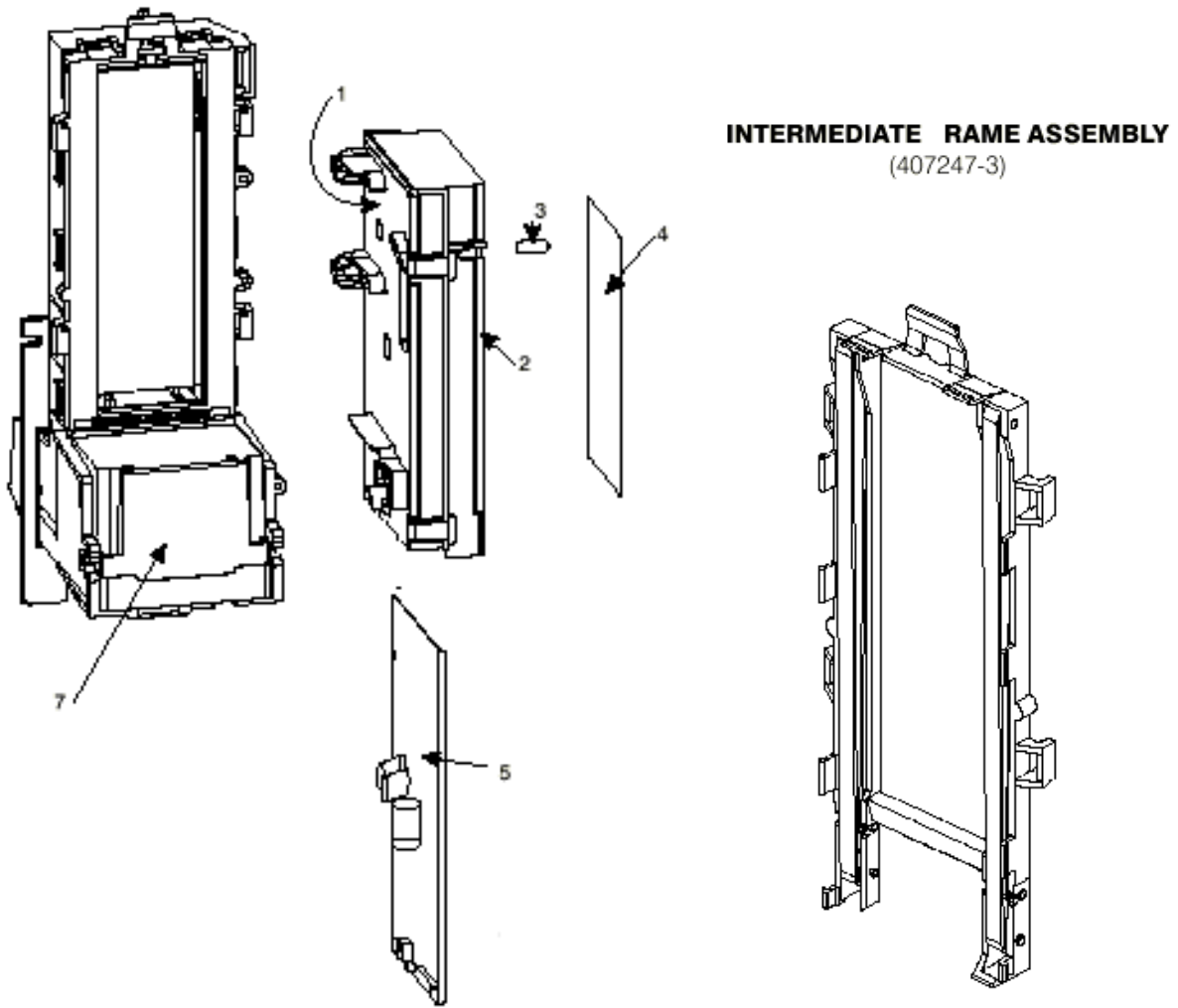

ITEM NO.	PART NO.	DESCRIPTION
1	922804	Logic Box Lid
2	408066	Logic Box Assembly
3	922563	Clear Decal
4	923388	MAG Decal
5	408049	MAG50B Logic Board
7	909729-2	Identification Label